

# IDM

(Ilkwang Dieprest Molding)

2004.01





# Agenda

---

- Auto parts trend
- Interior trim trend
- Interior trim
- Interior trim
- IDM(Ilkwang Dieprest Molding)
- IDM
- IDM
- IDM

# Trend



- CAFE(Corporative Average Fuel Economy)
- Bryan
- Partnership for a New Generation of Vehicles



- Life Cycle Assessment Program : FBB 95%



1992 5 ( )





# Interior trim trend



=>



- 가 가
  - Safety : Air bag, Side impact pad 가
  - HVAC : Air control duct 가
  - Comfortable : Holder , Map pocket
  - AV System : GPS, PC, ...



- Recycling ( )
- One shot process (Cost down)
- : VOC, ,

# Interior trim

	,		,	
	□		□	□□ ( )
			2	

	/		
	Dr Panel, Pillar, (HMC LZ, LX, EF)	Pillar, Dr Panel, (LZ PLR )	Dr trim (HMC EF, SM)
	PP,ABS PP	PP	PP (LG HF - 5150H )
	,	Cloth, PVC, PP Foam  Cloth  가	PVC,Cloth+PP Foam(15 )  Foam  15  가
C/T	50~90"	110~130"	90~110"



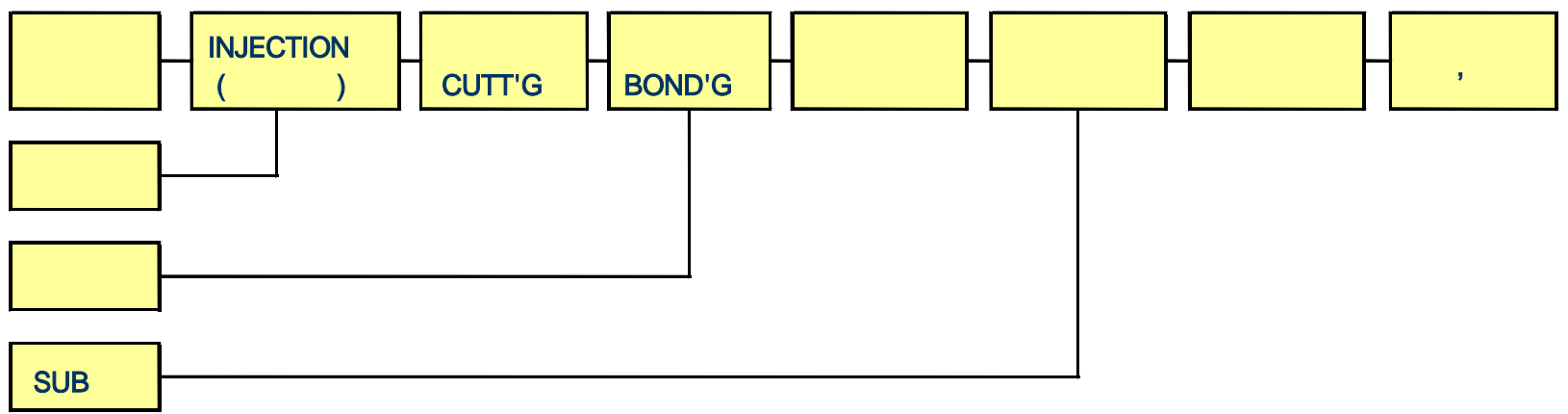
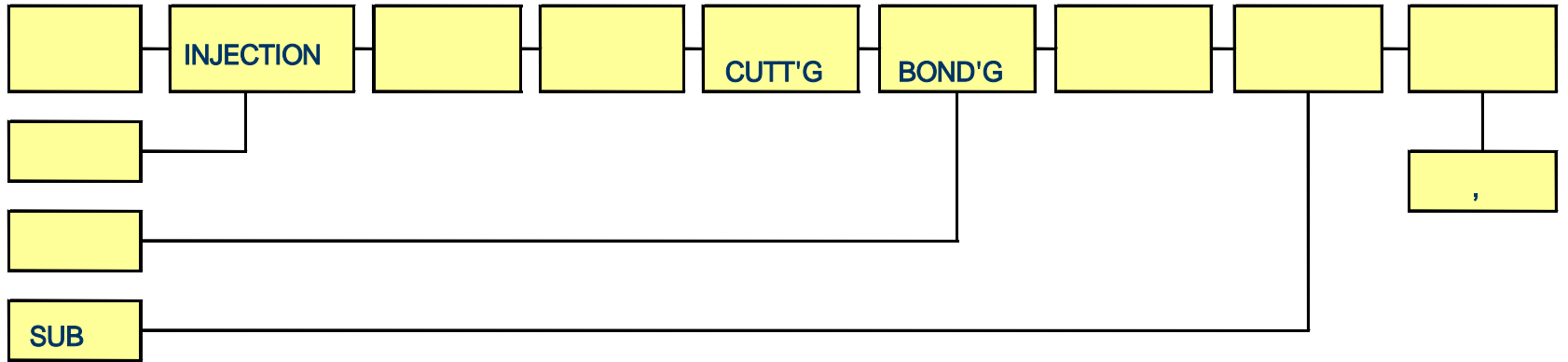

# Interior trim

1,		1,	One shot
2,	: Recycling	2,	( )
3,	,	3,	
4,		=> IDM	
		1,	> 가
		2,	>
		3,	>

● ● ● | **IDM**

?

○

가

, /

UBE

Dieprest Molding Process  
(Ilkwang Dieprest Molding)

●

●

●

●

●

;

;

,

( )

# IDM

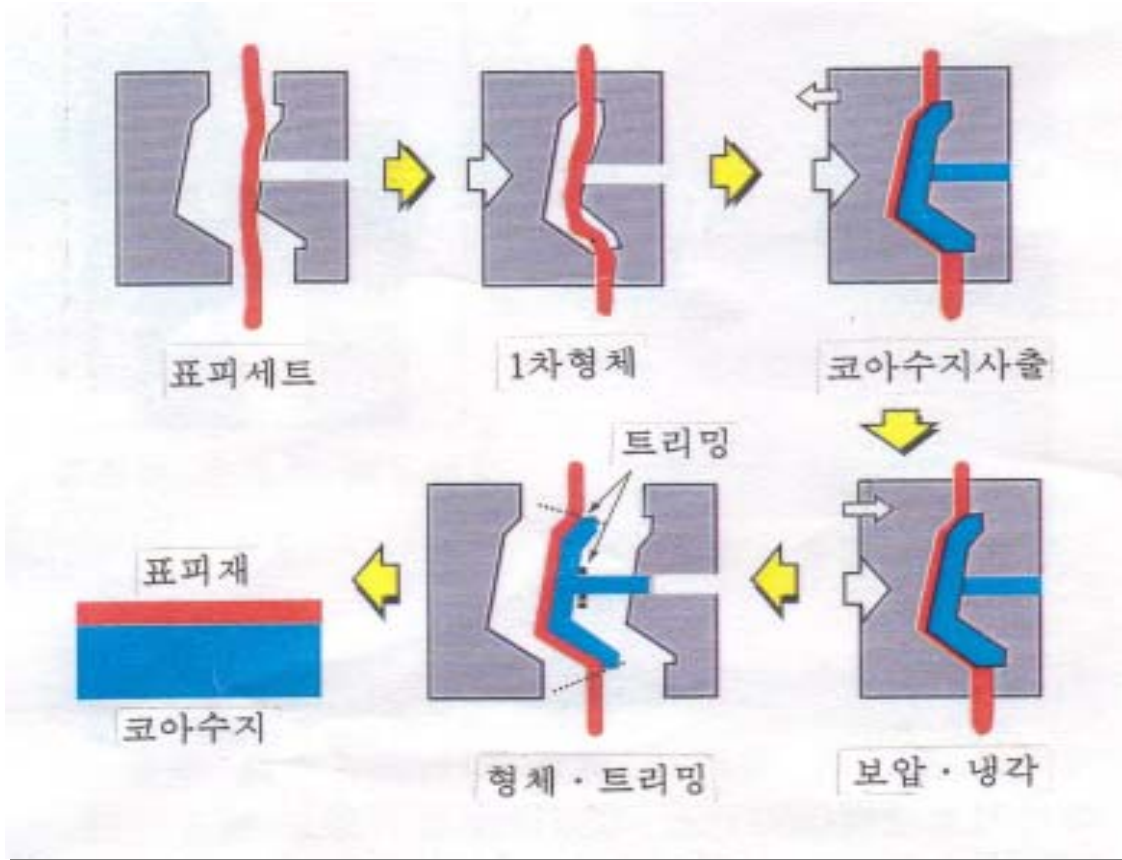

# IDM

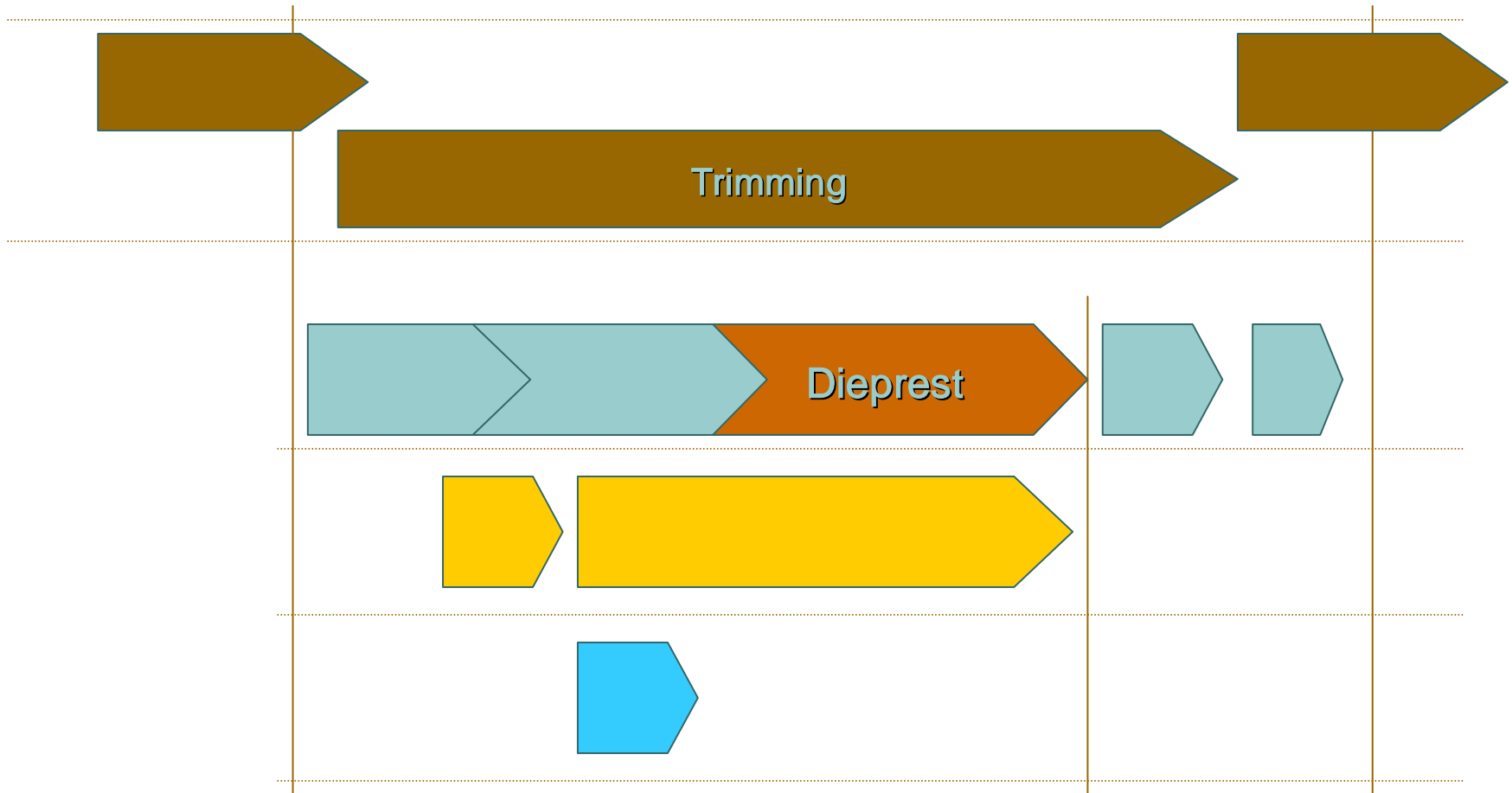

# IDM

가

가

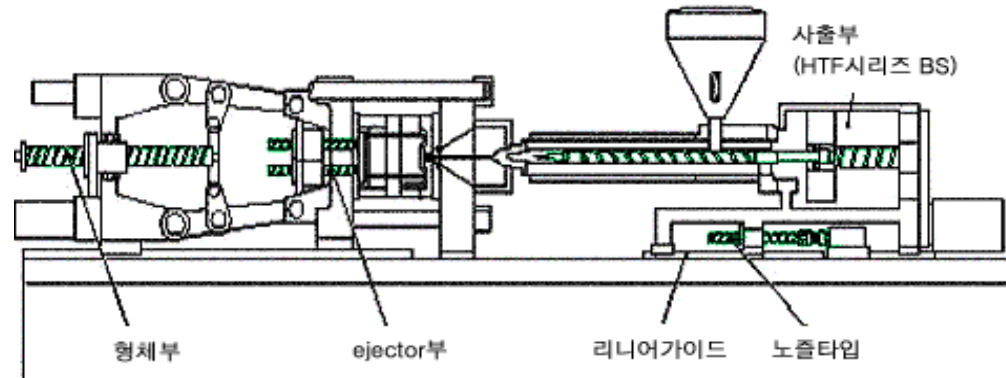

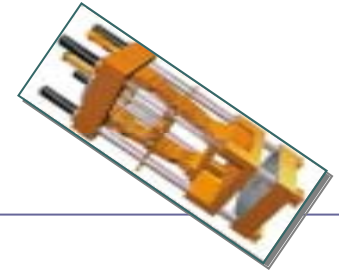

> 가

=100mm

=8mm

가 (1/100mm)

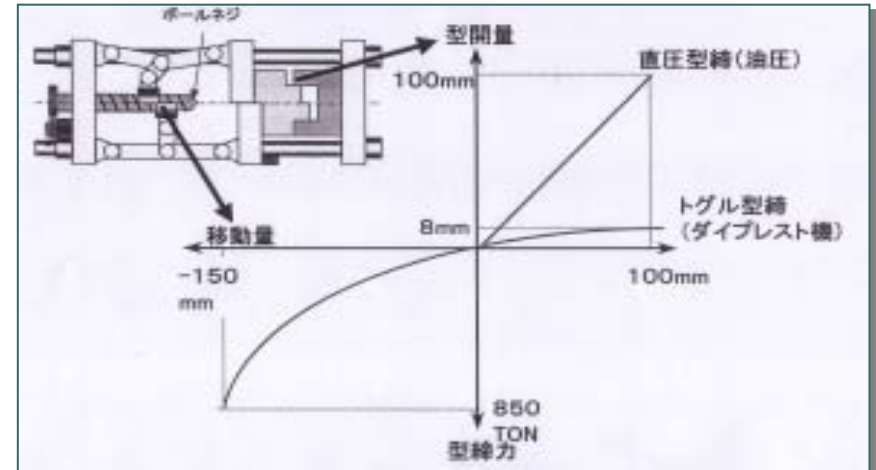
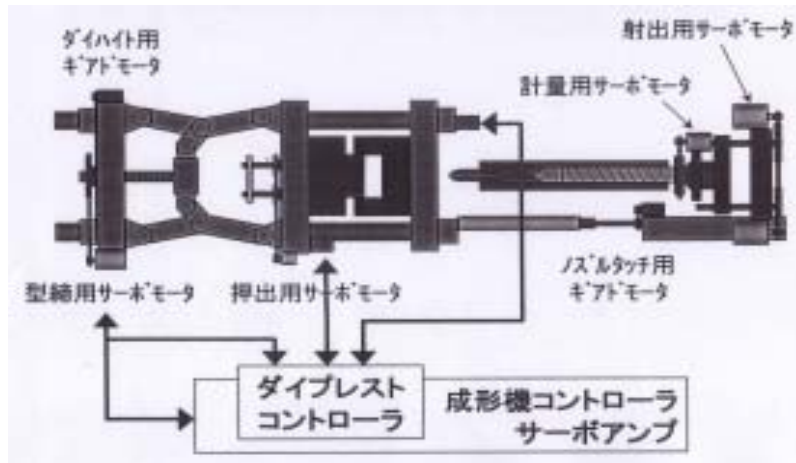

## (微少 型開)

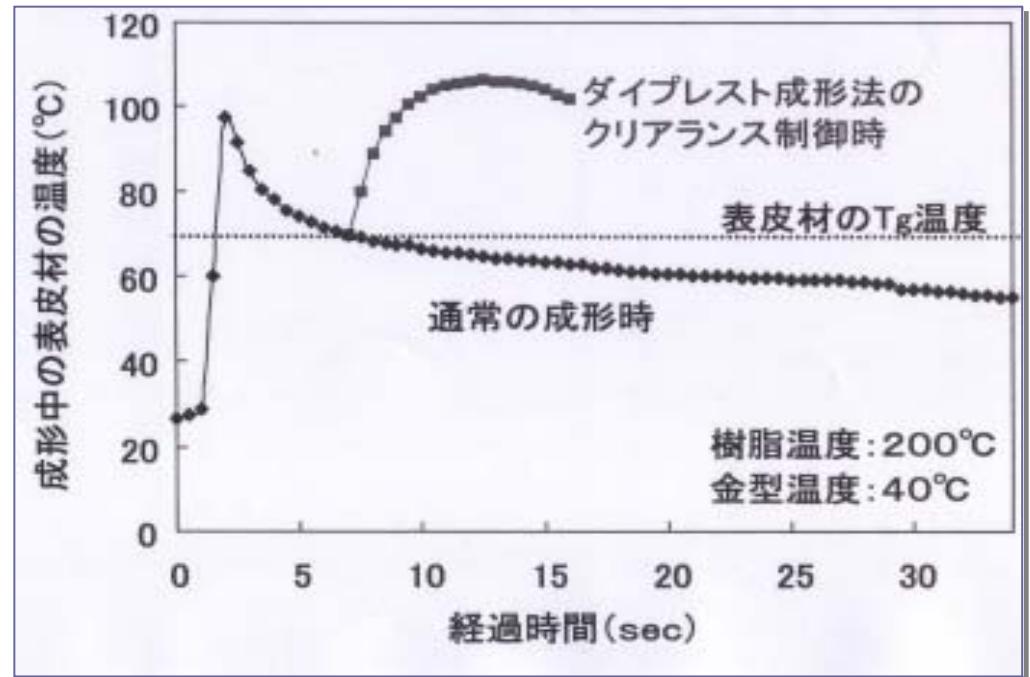
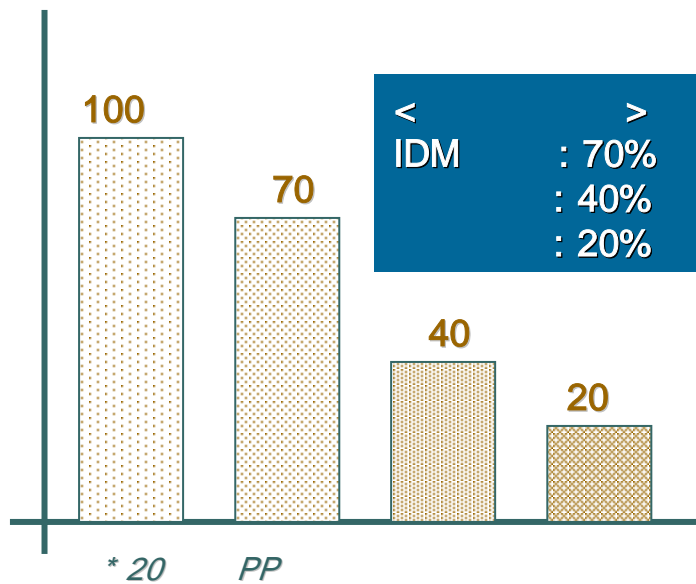

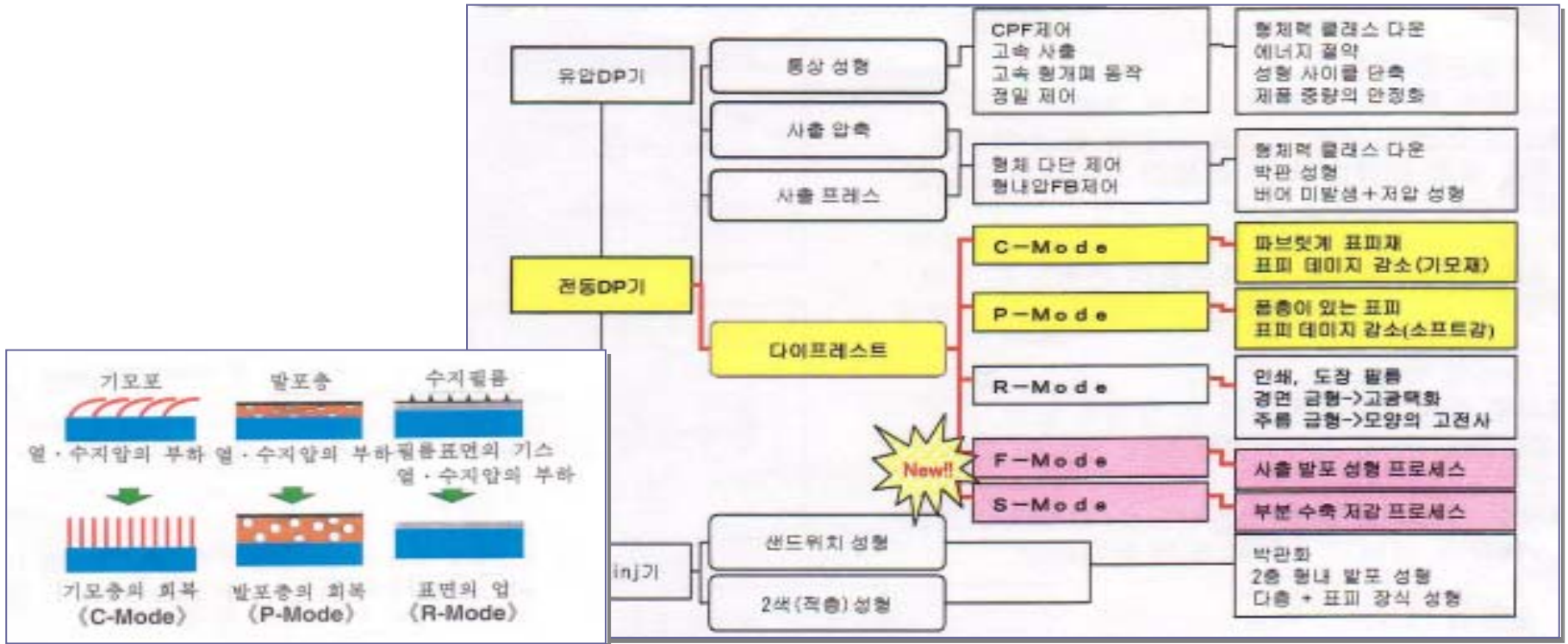

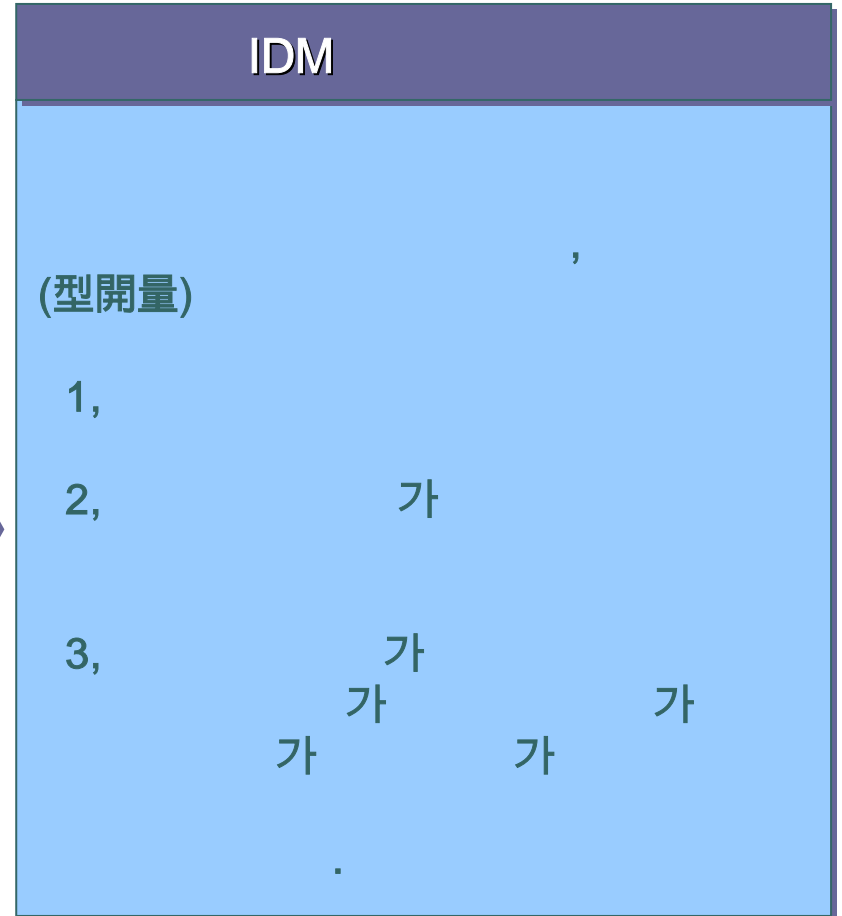
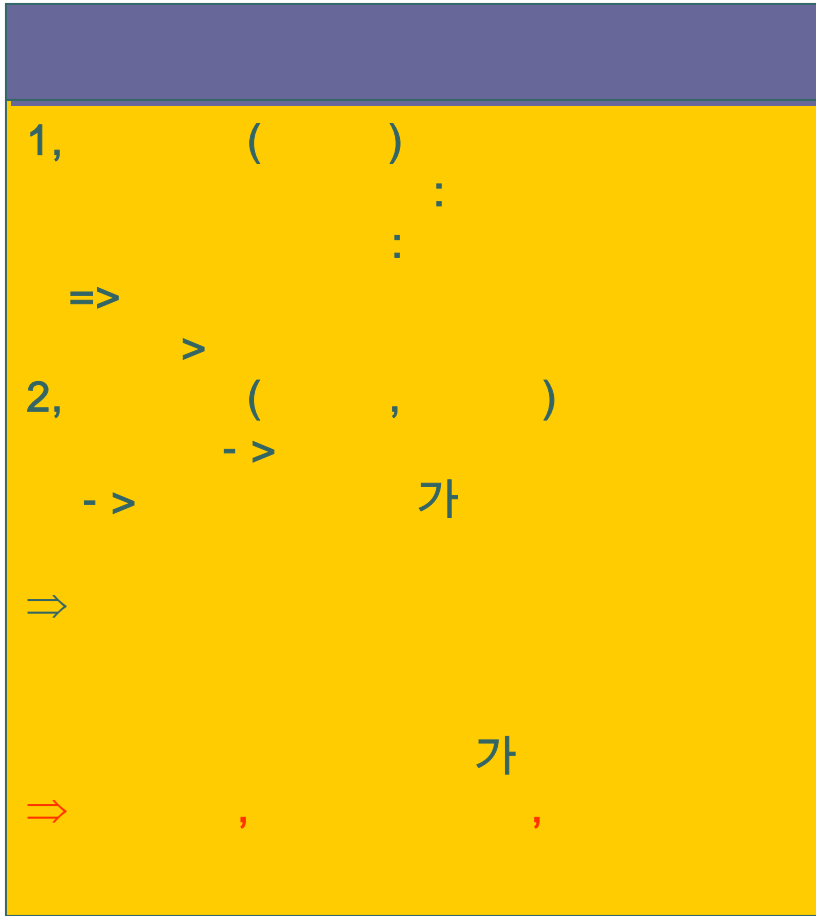

# IDM

## C / P Mode

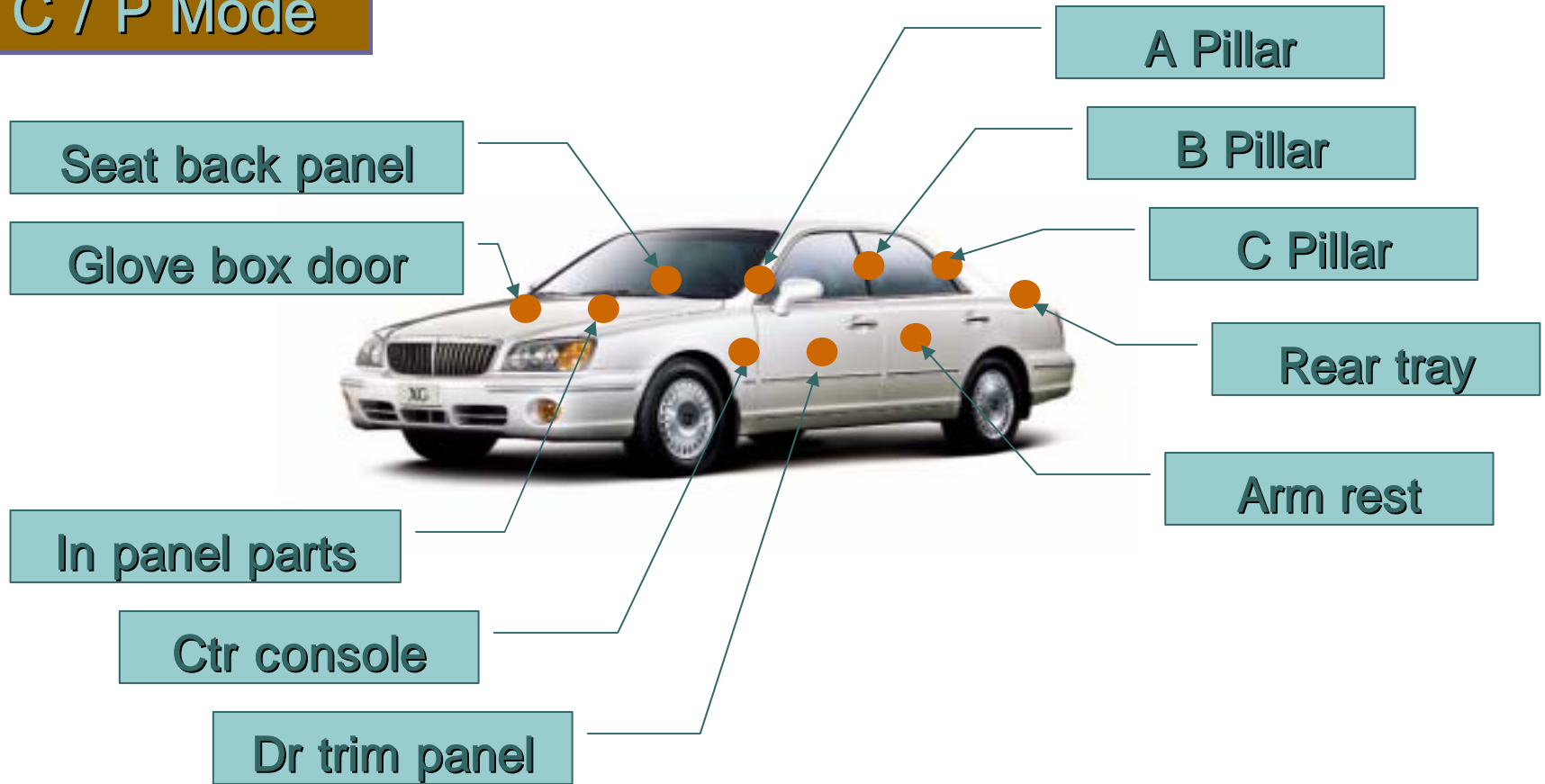

R Mode

In panel part

Ctr console

Bumper

Wheel cover

Side panel



# IDM

	14	A/B/C Pillar, In panel, Dr trim, Sun shade, Bumper, Interior trim,	<ul style="list-style-type: none"> <li>○ 가</li> <li>○</li> <li>○Soft</li> <li>○</li> <li>○</li> </ul>
Nissan	5		
Honda	4		
Suzuki	1		
	13		

